



STORK®



Heat Treatment Module

6 output

50kVA Part Number 16050

70kVA Part Number 16051

Stork Cooperheat (UK) Limited

Modern pressure part design places high importance on the integrity of welded joints. Where required successful heat treatment is essential, especially with high performance steels and requires equipment that can provide accurate control of the cycle parameters along with uniformity of temperature throughout the geometry.

Stork Cooperheat has a long history of innovation within the field of localised heat treatment equipment. As part of our commitment to continuing our innovative reputation, we take pleasure in introducing Stork Cooperheat's latest 50kVA and 70kVA Heat Treatment Modules, which include our latest 'Advantage 3' series of temperature programmers and controllers. Our new designs, based on almost 50 years experience as a market leader in the field of heat treatment, have been developed to meet the real needs of the heat treatment engineering industry.

Our designs were driven by the need to meet five key criteria:

Value for Money

When you compare the functionality and versatility of the new Stork Cooperheat heat treatment modules with other, similar, products in the market you will find that they significantly outperform our competitors, delivering a rapid return on investment.

Versatility

- Instant access to output channels that can be used to power either 30V or 60V heating elements without the need to change any tapings on the transformer or connect a wasted additional heating element in series.
- 'Advantage 3' digital temperature controllers/programmers operate in °C or degrees °F.
- Temperature controllers display both set point temperature and actual work piece temperature
- Transformer secondary tapings allow for supplying power to 30V or 60V heating elements
- Programmer/controller linking features allows the operator to carry out up to heat treatment cycles simultaneously.

Ease of operation and maintenance

- Clear, illuminated digital displays showing actual and set point temperatures
- LED indicator light indicating 'power on' for each output channel
- Input/output sockets are located on back panel.
- Simple access to transformer tapping board and for maintenance to instruments by means of a swing hinged front panel.
- Connectors provided for simple connection of primary supply cable.

Fitness for purpose.

- Constructed from high-grade stainless steel giving excellent protection against corrosion including marine offshore applications
- Large castor wheels to facilitate mobility in normal site conditions

Safety

- CE marked in compliance with European Safety Directives
- Safe voltages employed. Voltage to earth from any single output socket is 32.5V a.c.
- Automatic protection against transformer coil becoming over heated by inclusion of thermostats in the core windings
- Primary over-current protection provided by a three-phase circuit breaker.
- Low voltage systems and insulated cable connections eliminate risk of electrical shock to welders working on electrically preheated weld joints.

Our new 'Advantage 3' programmer/controllers provide the user with greater versatility, flexibility and cost savings.

These benefits are achieved by, utilizing an 'Advantage 3' programmer/controller which, when used either individually or combined in a number of user selectable configurations, allows the user to operate a six output heat treatment system on up to six separate heat treatment specifications at the same time.

The important benefit for the user being that, unlike most standard six-channel programmers, the 'Advantage 3' system achieves this with all control zone controllers which are combined in a separate and concurrently running group of from 1 to six, on any single work piece monitoring each other and automatically controlling any differential between separate control zones.

This control of temperature differential is an important requirement of international heat treatment codes and standards such as ASME, BS, EN, ANSI, DIN, etc.

The cost savings are achieved by reducing the number of standard six channel (single program) programmers normally requires to heat treat work pieces requiring different heat treatment cycles or where only one standard six channel (single program) programmer is available, eliminates the need to for multiple shift working to carryout several separate heat treatment processes for each heat treatment specification.

Diagrams (1) below and (2) on the following page demonstrate the difference

Diagram (1) - THREE WORK PIECES EACH REQUIRING DIFFERENT HEAT TREATMENT PROGRAMS USING THREE STANDARD SIX CHANNEL PROGRAMMERS

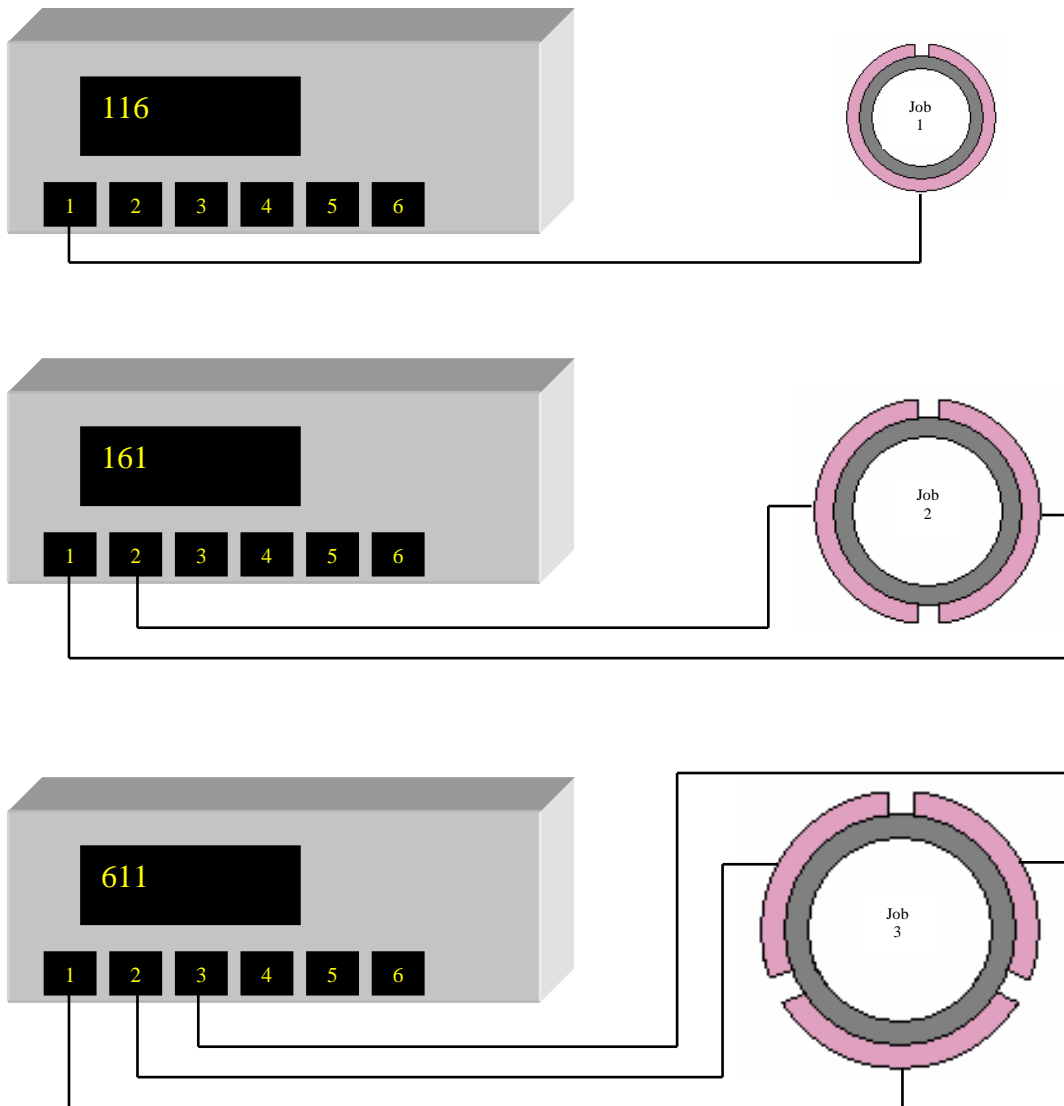

**'Advantage 3' programmer systems are available in multiples of three up to thirty-six channels.*

Specification

50kVA Module	70kVA Module
Transformer core:	
Three phase, forced air cooled, class H, 50kVA Primary winding connected in delta Secondary winding connected in star Auxiliary winding: 110V a.c. 3.3 kVA single phase	Three phase, forced air cooled, class H, 70kVA Primary winding connected in delta Secondary winding connected in star Auxiliary winding: 110V a.c. 3.3 kVA single phase
Primary supply:	
Primary Voltage: 380V, 415V, 440V, Primary current: 76A, 70A, 66A, Frequency 50/60 Hz	Primary Voltage: 380V, 415V, 440V, Primary current: 106A, 97A, 92A, Frequency 50/60 Hz
Protection:	
Three phase 80A circuit breaker with shunt trip. Three primary core winding over temperature thermostats linked to circuit breaker shunt trip.	Three phase 125A circuit breaker with shunt trip. Three primary core winding over temperature thermostats linked to circuit breaker shunt trip.
Secondary outputs:	
<ul style="list-style-type: none"> Output option A: 32.5V – 0V – 32.5V (for 30V and 60V heating element operation) Auxiliary outputs: Three 110V, 10A, 50/60Hz output sockets Number of temperature controlled output channels: 6 channels Maximum load per output channel: 8.1kW (e.g. three 60V, 2.7kW heating elements) Maximum current per output channel: 135A 	<ul style="list-style-type: none"> Output option A: 32.5V – 0V – 32.5V (for 30V and 60V heating element operation) Auxiliary outputs: Three 110V, 10A, 50/60Hz output sockets Number of temperature controlled output channels: 6 channels Maximum load per output channel: 10.8 kW (e.g. four 60V, 2.7kW heating elements) Maximum current per output channel: 180A
Construction:	
Case: 304 Stainless Steel case fitted with four 150mm nylon wheels Weight: 300 kg	Case: 304 Stainless Steel case fitted with four 150mm nylon wheels Weight: 300 kg
Temperature control:	
Features:- <ul style="list-style-type: none"> Temperature measurement, display and control: Degrees Fahrenheit or Degrees Centigrade Start temperature. Temperature ramp up and down in degrees per hour. Hold/soak temperature set point and hold/soak time period setting. 	
Switching:	
Six double pole, 180A, contactors with 110V a.c. coil.	

STORK® knows-how

Stork Cooperheat (UK) Ltd
 7 Glebe Road
 East Gillibrands
 Skelmersdale
 Lancashire
 WN8 9JP
 The United Kingdom
 Tel: +44 (0)1695 713500
 Tel: +44 (0)1695 713501
 Email:
info.heattreatment@stork.com
 Web: www.stork.com

The data in this leaflet was valid at the time of publishing, and is subject to change without notice. Stork Cooperheat reserves the right to modify its products at any time without further obligation.